



CM106B, CM106BK

7-to-10 ft Galvanized-Steel-Tubing Tripod and Tripod Kit



Sales & Support:
(435) 755-0774
<http://www.inmtn.com>
info@inmtn.com

Light, Adjustable, Rugged

Galvanized tubing is light, strong,
and corrosion-resistant

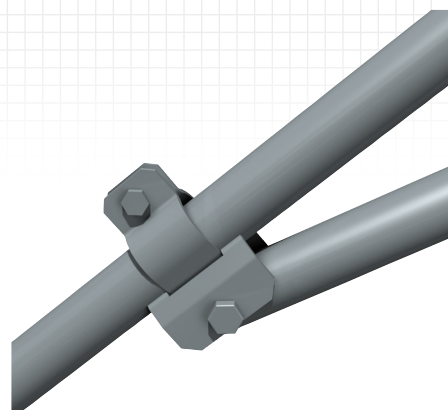
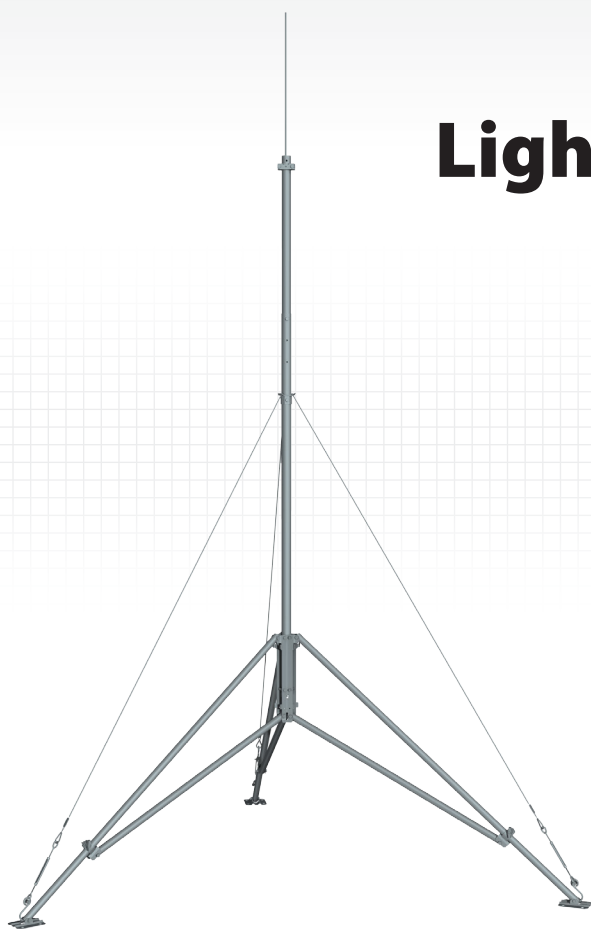

A close up of the adjustable leg clamp.

Overview

The CM106B is a general purpose tripod that can be used for mounting sensors, solar panels, antennas, and instrument enclosures. It is constructed from galvanized steel, with individually

adjusted legs that allow installation over uneven terrain. Height of the mast is 2.1 m (7 ft), or 3 m (10 ft) with the mast extension.

Benefits and Features

- › Support for meteorological sensors, hydrological sensors, sensor mounts, solar panels, environmental enclosures
- › Portable instrument mount
- › Ease of assembly, while maintaining high performance standard
- › Lightning and grounding rods, grounding cables, grounding cable clamps, ground stakes, and UV-resistant cable ties included
- › Enclosures can be mounted on tripod leg, as well as mast
- › Enclosures mount higher on the leg

Technical Description

The CM106B includes lightning and grounding rods, grounding cables, UV resistant cable ties, the 30338 mast extension kit, and stakes for securing the tripod feet to the ground. An optional guy kit is recommended for sites that may experience high wind speeds. Instrument enclosures can be purchased with mounting brackets that attach to either the mast or leg base.

The CM106B can be used for a variety of applications. For meteorological stations, sensors are mounted to the tripod using mounting brackets appropriate for the model of sensor. For non-meteorological applications, the tripod can be used to mount instrument enclosures, solar panels, junction boxes, or antennas.

questions & quotes: 435.227.9120

www.campbellsci.com/cm106b



CM106BK Tripod Kit

The CM106BK Tripod Kit is intended for overseas customers. It contains hardware for constructing a tripod. The galvanized steel pipes used for the mast, legs, and leg braces are purchased locally, which greatly reduces overseas shipping costs. Specifically, the customer will need to purchase the following:

- Mast—(1) DN 40 mm (1 1/2 in. NPS) steel pipe with 181.6 cm (71.5 in) length
- Legs—(3) DN 25 mm (1 in. NPS) steel pipes with 179.1 cm (70.5 in) length
- Leg Braces—(3) DN 25 mm (1 in. NPS) steel pipes with 119.4 cm (47 in) length

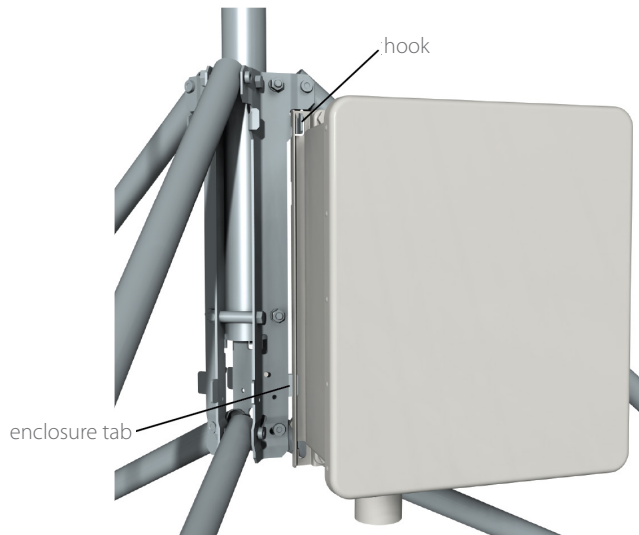

An enclosure mounted to the leg base of the CM106B.

Ordering Information

Tripod and Tripod Kits

- CM106B** 2.1 m (7 ft) or 3 m (10 ft) galvanized-steel tripod with grounding kit
- CM106BK** CM106B Tripod Kit

Common Accessory

- 29813** Optional tripod guy kit for the CM106B

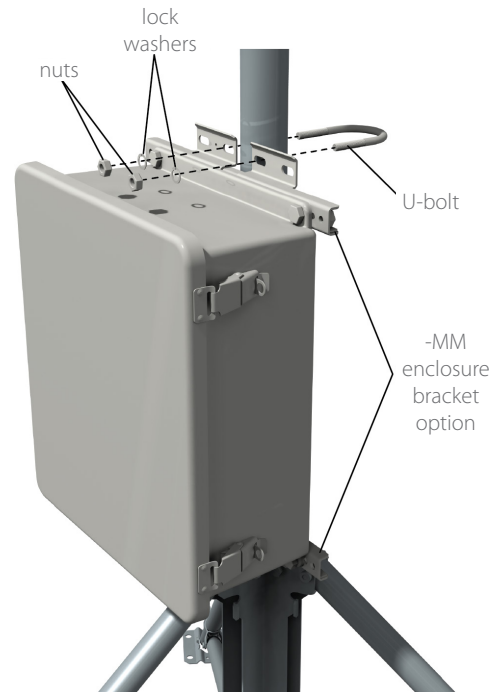

An enclosure mounted to the mast of the CM106B.

Specifications

- Measurement Height
 - Upper Mast Retracted: 2.1 m (7 ft) to 2.8 m (9.3 ft)
 - Upper Mast Extended: 3 m (10 ft) to 3.7 m (12.3 ft)
- Vertical Load Limit: 200 kg (440 lb)
- Mast Outer Diameter
 - Main Lower: 48 mm (1.90 in)
 - Retractable Upper: 44 mm (1.74 in)
- Base Diameter: 2.7 m (8.7 ft) to 3.5 m (11.5 ft)
- Leveling Adjustment: Slide collars on each leg adjust individually
- Leg Base: 11.3 cm (4.5 in) by 14.0 cm (5.5 in) with four 15.5 mm (0.62 in) holes for stakes
- Portability: Collapsible to 20.3 cm (8 in) diameter by 1.8 m (6 ft) length

- Maximum Slope Angle: 45° or 100% grade
- Weight with Mast: 24.5 kg (54 lb)
- View EU Declaration of Conformity documentation at: www.campbellsci.com/cm106b
- Maximum Allowable Wind*

Tripod Configuration	Sustained Wind	Wind Gust
Mast Extended, Unguyed	28 m s ⁻¹ (62 mph)	36 m s ⁻¹ (81 mph)
Mast Retracted, Unguyed	36 m s ⁻¹ (80 mph)	46 m s ⁻¹ (104 mph)
Mast Extended, Guyed	45 m s ⁻¹ (102 mph)	59 m s ⁻¹ (132 mph)
Mast Retracted, Guyed	55 m s ⁻¹ (122 mph)	71 m s ⁻¹ (159 mph)



Sales & Support:
 (435) 755-0774
<http://www.inmtn.com>
info@inmtn.com

*Allowable wind speed values assume an ENC14/16 enclosure mounted to leg; an SP10 solar panel mounted at the mast base; sensors with a 0.13 m² (1.4 ft²) projected area that's mounted at the mast top; guy wires attached to mast at 3.8 ft above tripod body; and adequate ground anchors (stakes alone may not resist foot vertical pullout force); see Appendix A of CM106B manual for more information on maximum allowable wind speeds.